

# TRANSEC CL SERIES

ONLINE MOISTURE  
MONITORING & DRYING  
SOLUTIONS  
FOR OIL INSULATED  
TRANSFORMERS



# THE ISSUE: MOISTURE IS THREATENING THE TRANSFORMER

Moisture is one of the primary causes of failures for power transformers and one of the main degradation factors for the insulation paper. It, therefore, increases the risks of operation failures and shortens the life expectancy of the asset.

Unfortunately, moisture can appear in a transformer from several sources, which are external or internal and it has a complex dynamic between the oil and paper within the transformer. The use of silica gel breathers, sealed tanks or nitrogen blankets can avoid all or at least the most of moisture from the atmosphere to affect the transformer. However, when the transformer is energised, the production of water inside the insulation is a natural and inevitable occurrence over time due to the depolymerisation of the cellulose paper.

## EFFECT ON SAFETY

As shown in figure 1, the higher the relative water saturation, the lower the oil's breakdown voltage (BDV). As water migrates between the solid and liquid insulation in a transformer with changes in load and, therefore, temperature so does the relative water saturation in oil.

Peaks of relative saturation are usually observed during transformer state changes (high to low temperature or reverse). Moisture reduction is, therefore, a pivotal effort to be made to increase safety, especially for transformers with quick and frequent load changes.

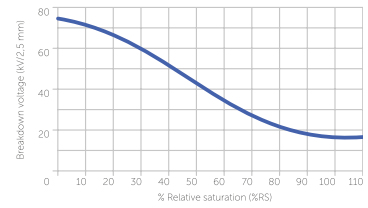

Figure 1. Dependency between breakdown voltage and water content in insulating liquid\*

## EFFECT ON TRANSFORMER LIFE EXPECTANCY

The insulation paper's mechanical strength is defined by the degree of polymerisation, also called DP, representing the average length of cellulose chains in the paper. A new transformer typically has a DP between 1200 and 1000 while the end of transformer life is considered when the DP falls to 200. This degradation cannot be stopped, but its speed will depend on the water content in the paper (see figure 2).

In CIGRE brochure D1.01.10 (2007), "Fallou showed that the rate of degradation of the paper at an initial value of 4% water content was 20 times greater than that at 0.5 % water content."

Moisture is having a significant effect on the speed of paper degradation and therefore on its life expectancy.

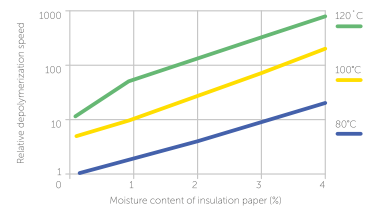

Figure 2. Cellulose depolymerisation speed dependence on moisture content in insulation paper for different temperatures\*\*

Maintaining a low level of moisture in a transformer provides significant benefits in terms of operations and risk as it carries a constant high insulation level. It is therefore possible to load the transformer at a higher level and to make this load vary without risk of damaging the transformer.

Also, it has consequent financial benefits since it elongates the asset's life by slowing down the paper degradation. This degradation creates particles or even sludges. Finally, moisture is also responsible for the creation of acids in the oil. Hence keeping a low level of moisture will lower the maintenance costs.

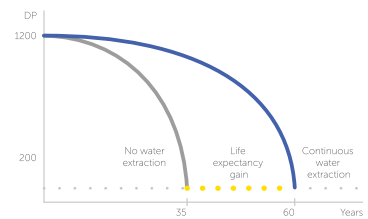

Figure 3. Benefit of continuous online drying system

\* CIGRE Moisture measurement and assessment in transformer insulation – evaluation of chemical methods and capacitive moisture sensors, page 10

\*\* CIGRE Moisture measurement and assessment in transformer insulation – evaluation of chemical processes and capacitive moisture sensors, page 14

## ONLY CONTINUOUS FILTRATION IS EFFICIENT IN REMOVING MOISTURE FROM A TRANSFORMER

As moisture is created continuously and as it is one of the primary concern for the transformer safety and life expectancy, it seems counter-intuitive to apply a temporary solution for this ongoing problem.

Also it is essential to note that more than 98% of the water in a transformer is in the paper, while a meagre amount is dissolved in oil. The diffusion time of water from paper to oil is prolonged. This is why punctual filtrations are not solving the moisture issue.

	Oil filtration	LFH or similar method	Online drying system
Solution type	Temporary	Temporary	Continuous
Transformer live during process	Up to user risk assessment (oil flow >500l per hour)	No	Yes
Dries oil	Yes	Yes	
Dries paper	No		
Improves Breakdown voltage	Temporarily (months)		
Extend life expectancy	No	No	
Dissolved Gasses level maintained			
Operator free process			
Cost	\$	\$\$\$	\$

# TRANSEC CL1I, CL2I, CL3I ONLINE DRYING SYSTEM

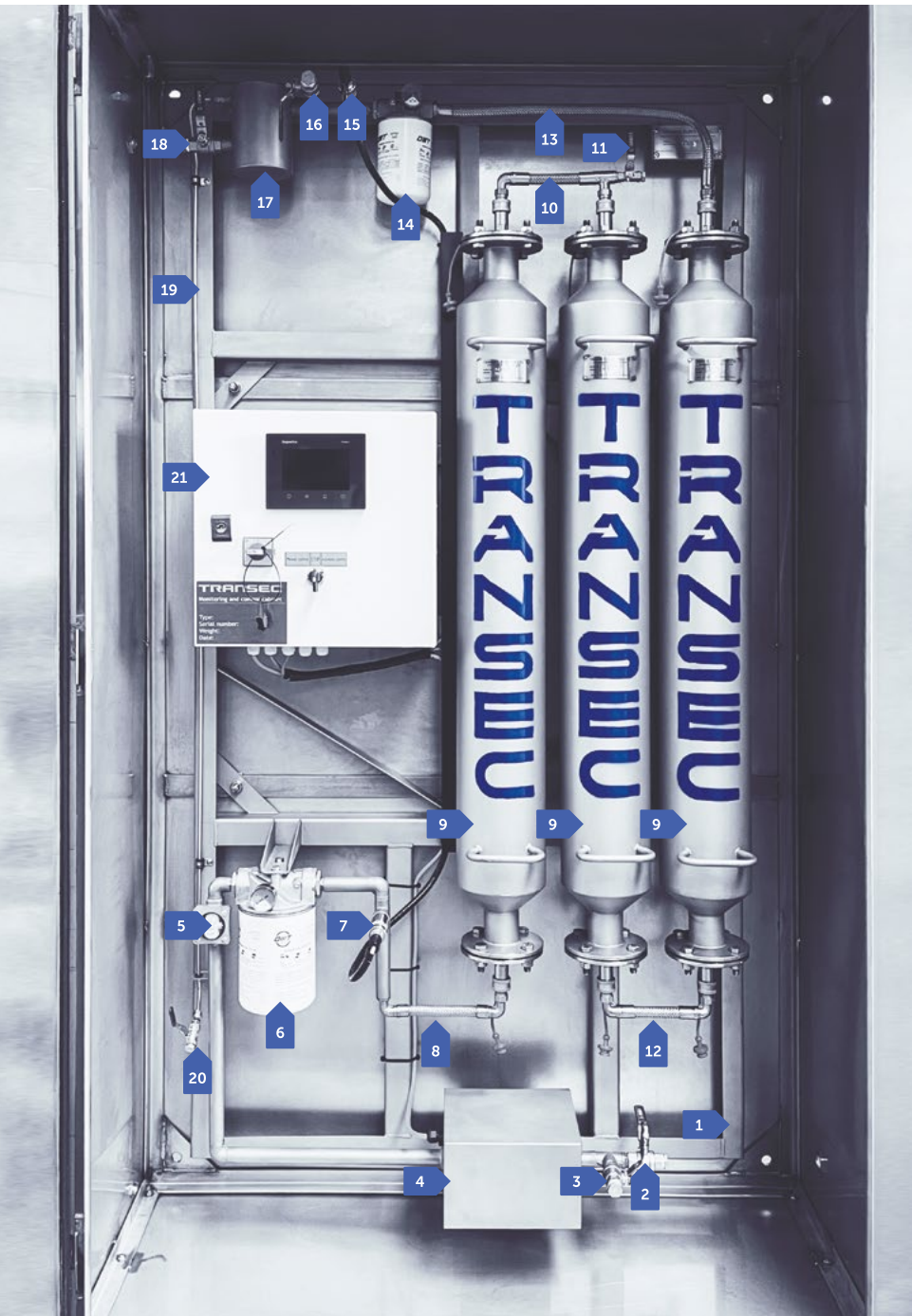

## PRINCIPLE OF OPERATION

Oil from the transformer tank through inlet ball valve 2 enters the unit. Pump 4 pushes the oil through inlet filter 6 and put it into cylinders 9. While the oil flows through the cylinder, the adsorption process takes place, moisture is adsorbed by zeolite. The oil is returned to the main tank of the transformer through outlet filter 14, deaerator 17 and outlet ball valve 18.

1. Frame
2. Inlet ball valve
3. Inlet sampling valve
4. Pump
5. Flow indicator
6. Inlet filter
7. Inlet moisture and temperature sensor
8. Bottom interconnection pipeline between cylinder and sensor/inlet filter
9. Cylinders
10. Top interconnection pipeline between cylinders
11. Air bleed valve between cylinders
12. Bottom interconnection pipeline between cylinders
13. Top interconnection pipeline between cylinder and outlet filter
14. Outlet filter
15. Outlet moisture and temperature sensor
16. Outlet sampling valve
17. Deaerator
18. Outlet ball valve
19. Bleed pipe
20. Deaerator air bleed valve
21. AMi monitoring and control cabinet (MCC)

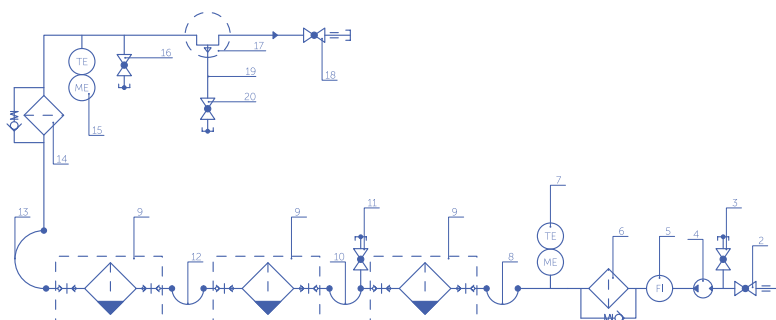

# TRANSEC CL UPGRADABLE VERSION: CL1I, CL2I, CL3I

CL1, CL2, CL3 technical data			
Parameter	CL1	CL2	CL3
Water extraction capacity before cylinder change	3 to 4 litres	6 to 8 litres	10 to 12 litres
Flow rate with Grundfos UPS2 pump	70 to 90 litres per hour		
Flow rate with TC500 pump	400 to 500 litres per hour		
Particle filter	10 microns on inlet & outlet. Optionally the unit can be fitted with an additional 3 microns pre-filter. Optionally the unit can be fitted with an additional 5 microns pre-filter for heavily sludged transformers.		
Material	Stainless steel 304 Grade		
Oil temperature range	0°C to 105°C		
Acceptable environment condition	-40°C to +60°C		
Altitude	up to 2000 m		
Protection class of the unit enclosure	IP55		
Protection class of the MCC enclosure	IP65		
Power Supply	240 V 50 Hz or 110V 60 Hz		
Pump Grundfos UPS2 Power	140 W		
Pump Midland TC500 Power	250 W		
Number of cylinders	1	2	3
Oil drying adsorbent	zeolite with 3 Angstrom bead size		
Monitoring	Available in option		
Size	1940 x 1000 x 300		
Installation weight without MCC	128 kg	164 kg	200 kg
MCC weight	00	AMi	WSi
	0.4 kg	12 kg	20 kg
Installation time	5 to 6 hours with 2 people		
Manufacturing type test	3 bar pressure at 110°C for 1 hour		
Manufacturing routine test	Cyclic 3 bar pressure at 60°C for 24 hours		
Enclosure	Optional. In stainless steel		
Fixation	On the wall or the ground		

CL1 WSi

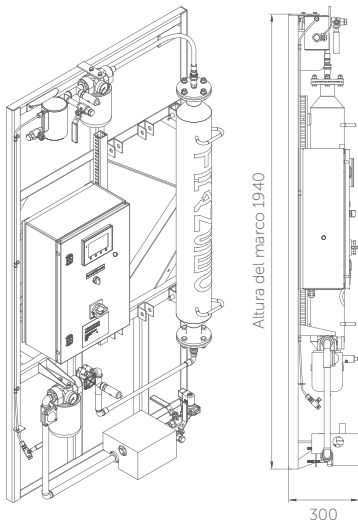

CL2 WSi

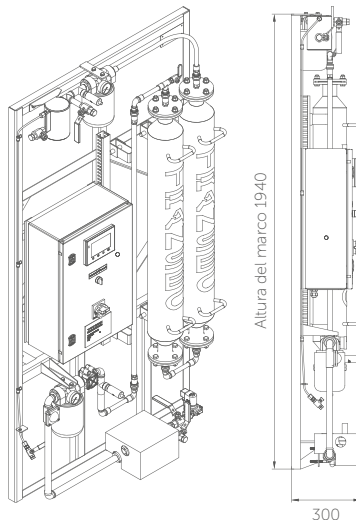

CL3 WSi

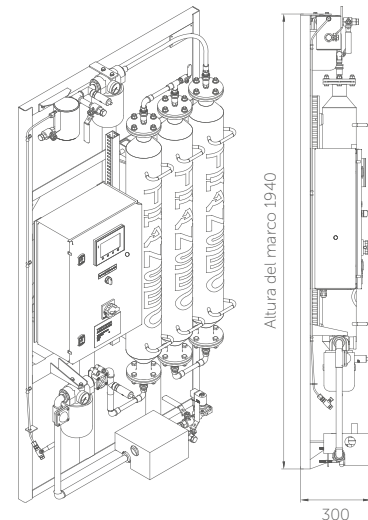

# CONTINUOUS MOISTURE ASSESSMENT WITH THE TRANSEC MONITORING

## MONITORING CABINET AMi

The AMi TRANSEC monitoring cabinet continuously monitors the temperature and moisture dissolved in the oil entering and exiting the TRANSEC. This allows monitoring the good water extraction for the TRANSEC but also the moisture level of the transformer. Alarms can be set, and reports of all data collected can be downloaded.



Picture of HMI

## MONITORING CABINET WSi

The WSi TRANSEC monitoring cabinet provides continuous monitoring of the temperature and the moisture dissolved in the oil entering and exiting the TRANSEC and allows to take action on it. The pump can be stopped under certain conditions. Also, other analyses are provided which will help to better understand the current moisture situation of the transformer and to take action.

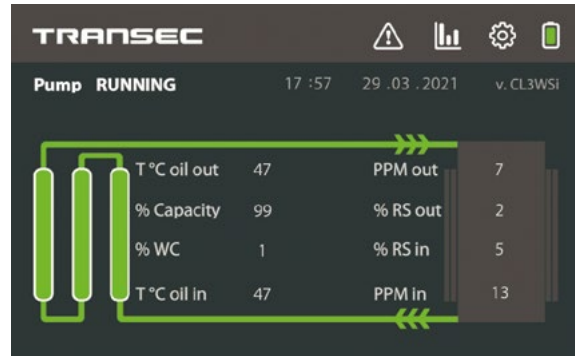

Picture of HMI

Monitoring cabinet AMi, WSi technical data		
Parameter	AMi	WSi
Local display	Oil temperature IN&OUT, PPM Moisture IN&OUT, Relative Saturation in, Pump and sensor status or alarm, Settings, Reports, Trends	Oil temperature IN&OUT, PPM Moisture IN&OUT, Relative Saturation IN&OUT, Water content in paper, Pump and sensor status or alarm, Settings, Reports, trends, Cylinder saturation level, Total water volume extracted
Data logging	Temperature IN&OUT, PPM IN&OUT, Relative saturation IN, Alarms	Temperature IN&OUT, PPM IN&OUT, Relative saturation IN&OUT, Water content in paper, Cylinder Saturation, Alarms
Alarms	SensorInDown, SensorOutDown, Overheat, %RS Alarm, AlarmReset, %CapacityAlarm, T°C IN, T°C OUT, PPM IN, PPM OUT	Pump status, SensorInDown, SensorOutDown, OverheatCab, LowFlow - Oil flow rate, l/h, Leakage, OverheatOil, Paper overdry, Alarm reset, FreezeOil - Oil temperature below the setpoint, %CapacityAlarm, %RS Alarm, T°C IN, T°C OUT, PPM IN, PPM OUT, Water Content - %WC alarm setpoint
Cylinders saturation	Saturation estimated based on the PPM IN&OUT difference	Calculated based on PPM and oil flow
Sensors	2x high accuracy moisture and temperature sensors	
Remote control	Alarm settings	Alarm settings, Pump stop & restart conditions
Communication	Via 3G/4G network or Ethernet: TCP/IP (VNC, HTTP, FTP/SFTP, MODBUS), USB stick	

# PRODUCT SELECTION GUIDE

## CL1I, CL2I, CL3I

TRANSEC unit	TR. CL.	X	X	X	X	X	X	X	X	i
Number of Cylinders	1 cylinder (4 litres of water extraction)	1								
	2 cylinder (8 litres of water extraction)	2								
	3 cylinders (12 litres of water extraction)	3								
Monitoring	No Monitoring		0							
	Monitoring with local display; PPM, Temp & %RS; Alarms		A							
	Monitoring with local display; PPM, Temp & %RS; Alarms; Analytics; Cylinder Saturation; automation		W							
Pump type	Grundfos UPS2 70 to 90 litres per hour			U						
	Midland TC500 400 to 500 litres per hour			T						
Mounting	Mounting on wall or on transformer. No standing frame.				0					
	Standing frame v1 to be bolted on the ground				1					
	Standing frame v2 self standing				2					
	Enclosed in Stainless Steel IP55 fixed on the ground or on a wall				3					
Pump/Power Supply	50Hz 240VAC					5				
	60Hz 120VAC					6				
Oil inside cylinders	Un-inhibited naphthnic oil IEC 60296						U			
	Inhibited naphthnic oil IEC 60296						I			
	Other (please specify)						O			
Filters	2x standard filters: inlet & outlet 10 microns							0		
	Inlet 3 microns & outlet 10 microns							1		
	Inlet & outlet 3 microns							2		
	Inline stainless steel 5 microns							3		
	Prefilter Pall 5 microns & outlet 10 microns							4		
	Prefilter Pall 5 microns & Inline stainless steel 5 microns							5		
Version										i

# PRODUCT SELECTION GUIDE

## CL1I, CL2I, CL3I

Monitoring unit	
TR.MT.00AM.0i.WW	Monitoring with local display; PPM, Temp & %RS; Alarms
TR.MT.00WS.0i.WW	Monitoring with local display; PPM, Temp & %RS; Alarms; Analytics; Cylinder Saturation; automation
TR.SR.MONI.UP.WW	Service for Monitoring box installation
Communication option	
TR.MT.RTGS.00.WW	GSM Router (2G,3G and 4G(LTE))
TR.AC.GTW.61850	IEC 61850 Gateway added in Monitoring cabinet (MODBUS TCP Converting to IEC - TCP ETHERNET & FIBER OPTIC OUTPUT)
Accessories	
TR.AC.NCYL.03.0i	3 new cylinders i Version + 2x replacement particle filters (10 microns)
TR.AC.IKIT.00.WW	Installation kit: 2x Male Stud Couplings, 1x Reducing tee, 1x Brass stud coupling, 3m copper tube, 1x Non return valve, 2x 2m tube SS 15mm cold annealed
TR.AC.IKIT.01.WW	Installation kit with flexible pipes stainless steel braided (7m & 10m)
TR.AC.ENCL.S1.0i	Stainless Steel Enclosure with insulation for CL1
TR.AC.ENCL.S3.0i	Stainless Steel Enclosure with insulation for CL3
TR.AC.ENCL.P3.0i	Powder Coated Enclosure with insulation for CL3
TR.AC.FLAN.15.WW	Flanges for installation DN15
TR.AC.FLAN.25.WW	Flanges for installation DN25
TR.AC.FLAN.50.WW	Flanges for installation DN50
TR.AC.FLAN.00.WW	Flanges for installation (size to be specify)
TR.AC.LEAK.00.WW	Leak tray & sensor*
TR.AC.GGAU.00.WW	Glass Gauge on dearator
TR.AC.RVLV.00.WW	Dearator level alarm switch*
TR.AC.SLSV.0i.WW	1x inflow controllable solenoid valves *
TR.AC.HTCA.00.WW	Heater for monitoring cabinet
Services	
TR.SR.REGE.03.WW	Regeneration of 3 cylinders (EXW UK)
TR.SR.SINS.00.WW	Installation Supervision
TR.SR.INSP.00.WW	Transformer inspection
TR.SR.MONI.UP.WW	Service for Monitoring box installation
TR.SR.MODI.00.WW	Product modification service
* only available for the WSi version	

# MORE THAN 3000 UNITS INSTALLED

Nuclear power	
	
UK	EDF ENERGY
Nuclear power plant	80 units in operation



Wind power	
	
UK	NNG
Wind farm offshore generation	6 units in operation

Hydroelectric generation	
	
Argentina	SALTO GRANDE
Hydroelectric power plant	20 units in operation

Power generation waste to energy	
	
Texas (USA)	COVANTA
Power Generation Waste to Energy	1 unit

Electricity generation	
	
Zambia	ZESCO
Kafue gorge hydroelectric power station	11 units in operation

Metal industry	
	
UAE	EGA
50 units in operation	

Transmission	
	
Cambodia	EDC TRANSMISSION
9 units in operation	

TRANSEC ELECTRIC LTD.  
51 Hollands Road, Haverhill, Suffolk CB9 8PL,  
UK

office@tr-electric.uk  
www.tr-electric.uk

STREAMER ELECTRIC AG, HQ  
Technopark Graubünden, Bahnhofstrasse 11, 7302 Landquart,  
Switzerland

+41 81 2500525  
office@streamer-electric.com  
www.streamer-electric.com

STREAMER CHINA  
11th floor, Building A. Sanlitun SOHO, Workers Stadium North Road  
No.8 Yard., Chaoyang District, Beijing, China

+86 8565 1663  
office\_bjs@streamer-electric.com

STREAMER INDONESIA  
Wilson Walton Building, Jl. Raya Tanjung Barat 155 Jagakarsa,  
Jakarta, Indonesia

+62 21 7884 0737  
office\_jkt@streamer-electric.com